

STRATO

INSTRUCTIONS FOR USE

Sizes 1 & 2

Codes 10041 & 10042



CONTENTS	PAGE
1.0 INTRODUCTION	1
2.0 ILLUSTRATION OF YOUR CHAIR	2
3.0 FOR YOUR SAFETY	3
4.0 TECHNICAL TABLE	4
5.0 UNPACKING YOUR CHAIR	5
6.0 SETTING UP AND ADJUSTING YOUR CHAIR	5
7.0 CARE AND MAINTENANCE	11
8.0 GUARANTEE & SERVICE	12
9.0 CONTINUOUS IMPROVEMENT	13
10.0 WARRANTY & AFTERSALE	14

1.0 INTRODUCTION

Thank you for choosing the Smirthwaite Strato Chair.

Strato is an innovative chair designed for children who are able to get in and out of their chair independently but require minimal to moderate postural support when seated. The uniquely contoured seat tilts forward to encourage an extremely comfortable anterior tilt of the pelvis for improved stability as well as trunk and lower limb alignment. The Strato aims to enhance the user's function and cognitive development.

	<p>IMPORTANT!</p> <p>These instructions should be read by all therapists and carers using the equipment and should be retained for future reference. The Strato requires an assessment to establish the user's needs and should always be used under adult supervision.</p> <p>Any incorrect use of the product and failure to follow the instructions may put the user at risk or impede the function. If you have any queries using this product or wish for further copies, please do not hesitate to contact Customer Service department on T: +44 (0) 1626 835552.</p>
---	--

2.0 ILLUSTRATION OF YOUR CHAIR

- A. Handle Extension
- B. Handle
- C. Handy Hook
- D. Lumbar Prompt
- E. Pelvic Strap

- F. Armrest
- G. Personal Pocket
- H. Seat
- I. Footrest
- J. Castor

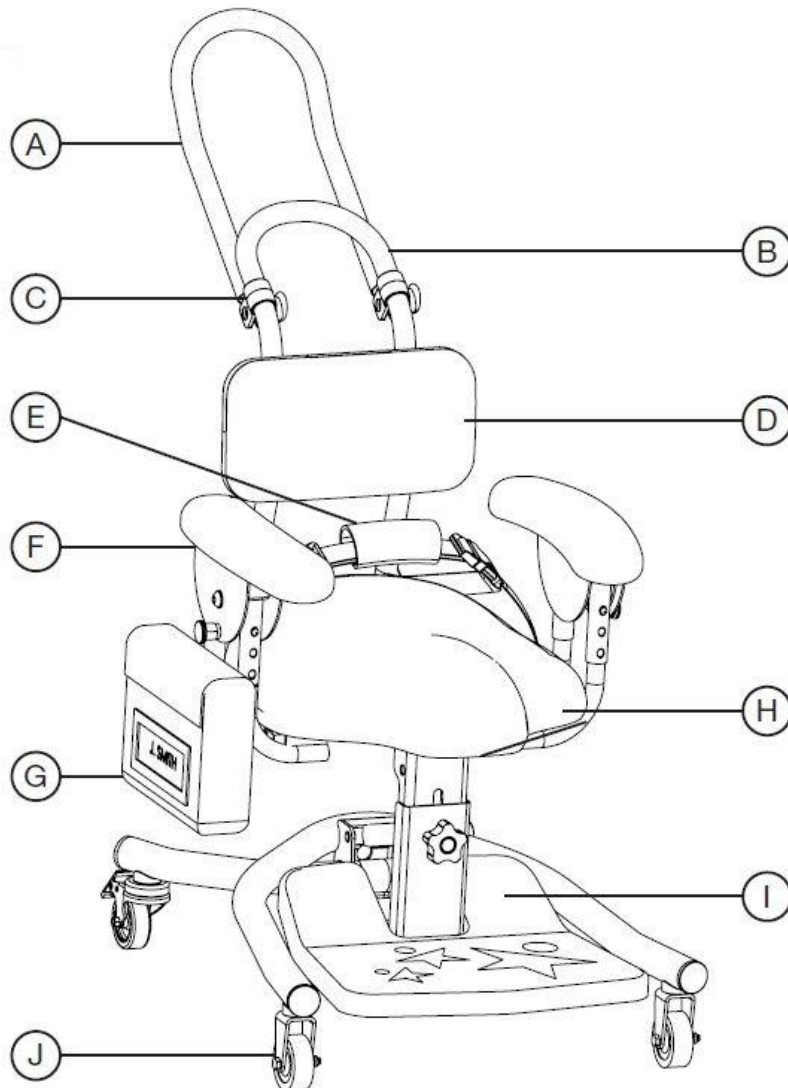

3.0 FOR YOUR SAFETY

	STOP!
	Please read these instructions CAREFULLY and THOROUGHLY

- The user should **NOT** be left unattended whilst in the chair. Always ensure a responsible therapist or carer is in attendance.
- The carer should be familiar with the methods of adjustment and have completed all adjustments appropriately to meet the needs of the child before transferring the child onto the chair.
- Regular maintenance checks and cleaning are essential for the safe use of this equipment (see care and maintenance section).
- Always fasten the pelvic strap and any other straps provided with the chair.
- Always lock at least two of the wheels when the chair is static.
- The castors of the Strato are designed for indoor use only, and may be damaged if used outdoors. The Strato should not be used as a transit chair.
- Regularly check that straps and/or harnesses are not showing signs of tearing or fraying, and that they fasten correctly.
- If any part is loose, damaged or functioning incorrectly, **DO NOT** use until rectified.
- Always keep this product away from naked flames, cigarettes and sources of heat including open fireplaces, radiators and heaters.
- **DO NOT** fit parts or accessories of other manufacturers to this product unless authorised to do so in writing by G&S Smirthwaite Ltd. Failure to follow these instructions will not only invalidate the guarantee but could make the chair dangerous to use. G&S Smirthwaite Ltd will not accept liability for any injury or damage incurred through such malpractices. Any repairs required must be carried out by G&S Smirthwaite Ltd authorised personnel.
- If you believe the chair or any fitted accessory to be faulty at any time, **DO NOT USE** – contact our Customer Service departments on +44 (0) 1626 835552.
- The Strato is CE marked. This certifies that it meets all relevant European safety requirements.

4.0 TECHNICAL DATA

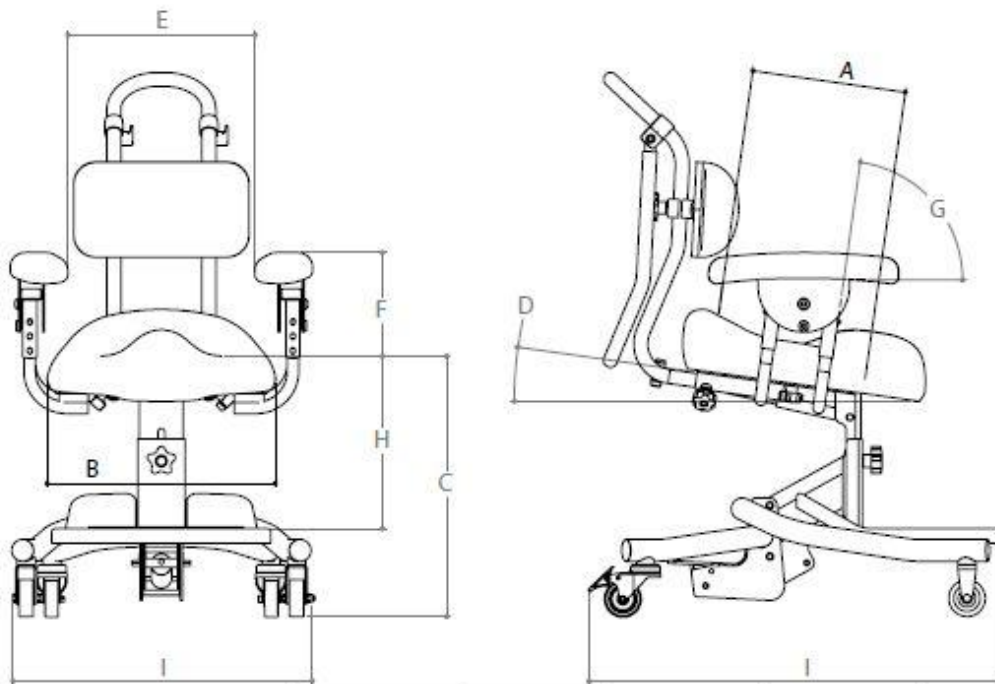

	SIZE	1	2	3	4	5
A	Seat depth	220	260	300	350	400
B	Seat width	250	290	370	450	450
C	Seat height	270-400	270-400	410-550	410-550	490-660
D	Seat angle (°)	0-15	0-15	0-15	0-15	0-15
E	Distance between armrests	240-300	300-360	370-470	440-550	440-550
F	Armrest height	120-160	120-160	170-230	170-230	170-230
G	Armrest angle (°)	+12 TO -12	+12 TO -12	+12 TO -12	+12 TO -12	+12 TO -12
H	Seat to footrest height	180-280	180-280	270-350	330-420	400-500
I	Footprint	W400-L490	W400-L490	W550-L650	W550-L650	W670-L660
	Weight limit (kg)	40	40	80	80	90
	Shipping weight (kg)	13	13.5	21.5	22	23

ALL DIMENSIONS ARE SHOWN IN MM

5.0 UNPACKING YOUR CHAIR

- When delivered, the Strato will be ready assembled as per your order.
- Please take note of any instructions on the packaging box when unpacking your Strato.
- Once the chair has been carefully unpacked, please check all parts.
- Ensure that all handwheels are securely tightened and that none are missing.
- If any part is loose, damaged or functioning incorrectly, do not use until rectified.

6.0 SETTING UP AND ADJUSTING YOUR CHAIR



STOP!

If in any doubt, **ALWAYS** seek **ADVICE**.

Always turn handwheels and screws clockwise to tighten or anti-clockwise to loosen. The chair must be fully adjusted by a therapist or trained representative before use.

IMPORTANT!



Always lock the castors when attaching items or making adjustments. To lock, apply foot to point (A), to unlock apply foot to point (B).

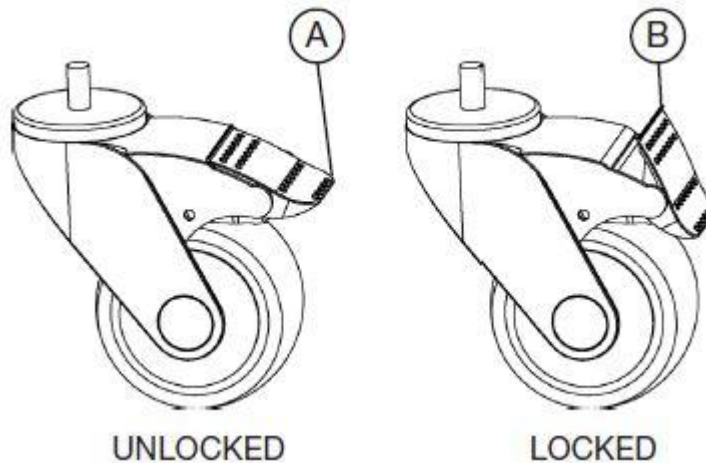

6.1 SEAT

6.1.1 SEAT ADJUSTMENTS

- Two adjustments can be made to the seat; height and angle.
- Adjustments can be made with or without the user seated in the chair.

6.1.2 HEIGHT

- Hold handle (A).
- Depress pedal (B) with foot.
- Adjust seat height to required position.
- Take foot of pedal (B).

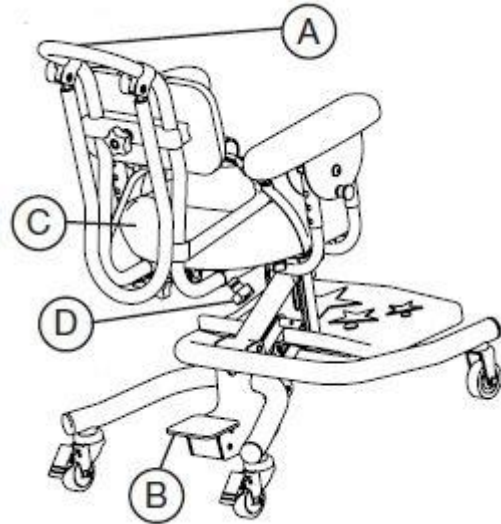

6.1.3 ANGLE (FORWARD TILT)

- Turn handwheel (D) clockwise to tilt the seat backward.
- Turn handwheel (D) anticlockwise to tilt the seat forward.
- Use adjustment indicator (E) to record angle of the seat.

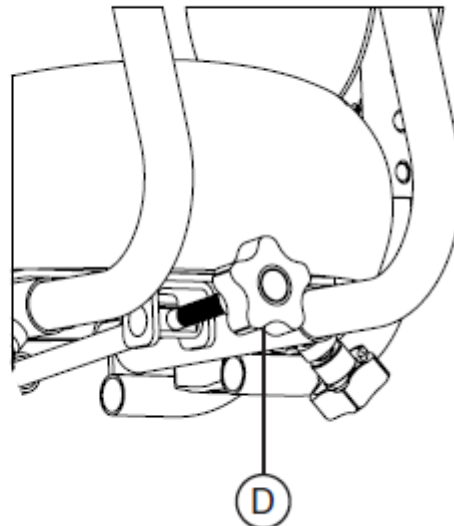
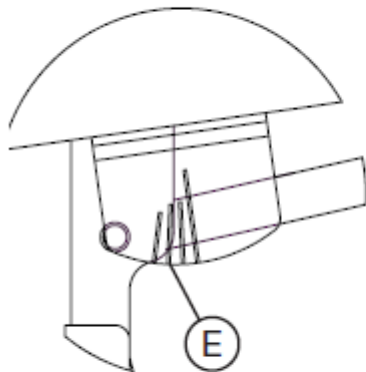

6.2 LUMBAR PROMPT

6.2.1 LUMBAR PROMPT ADJUSTMENT

- It is recommended that the lumbar prompt be correctly positioned at the user's lumbar region.
- Two adjustments can be made to the Lumbar Prompt; height and depth.

6.2.2 HEIGHT

- Loosen handwheel (A).
- Move lumbar prompt up or down to achieve the desired position.
- Re-tighten handwheel (A).

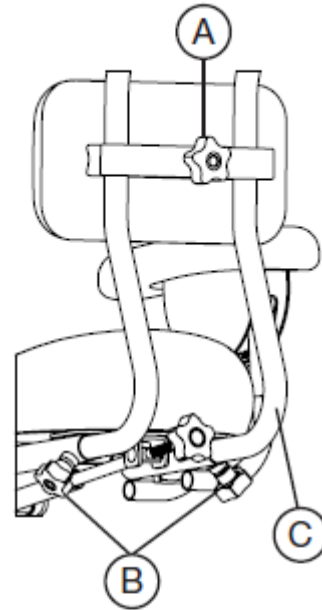

6.2.3 DEPTH

- Loosen handwheels (B).
- Slide lumbar prompt tubes (C) in or out to the desired position.
- Re-tighten handwheels (B).

6.2.4 LUMBAR PROMPT ATTACHMENT

- Insert ends of lumbar prompt tube (C) into receivers (D).
- Tighten handwheels (B).
- To detach, simply reverse the process.

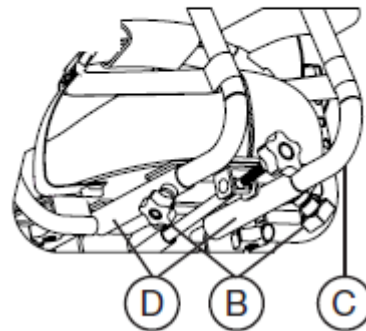

6.3 ARMRESTS

6.3.1 ARMREST ADJUSTMENT

- Three adjustments can be made to the armrests; height, width and angle.

6.3.2 HEIGHT

- Depress spring pins (A).
- Slide the armrest (B) up or down to the desired position.
- Ensure both spring pins are re-engaged.
- Repeat for the other armrest.

6.3.3 WIDTH

- Loosen handwheel (C).
- Slide armrest (B) in or out to desired position.
- Re-tighten handwheel (C).
- Repeat for the other armrest.

6.3.4 ANGLE

- Pull spring plunger (D).
- Tilt armrest (B) to desired position.
- Release spring plunger (D).
- Ensure spring plunger (D) is re-engaged.
- Repeat process for the second armrest

6.3.5 ARMREST ATTACHMENT

- For ease of attaching armrest, lay chair on its side.
- Hold armrest (B) under seat.
- Locate tab (E) in hole (F).
- Screw handwheel (C) into hole (G).
- Tighten handwheel (C) to secure.
- Repeat for second armrest.
- To detach, simply reverse the process.

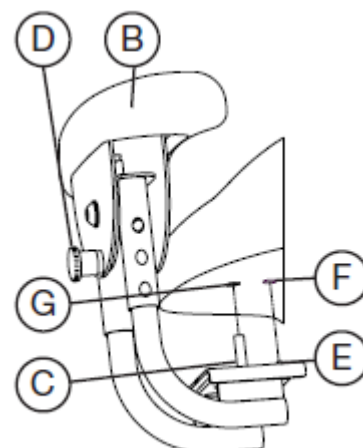
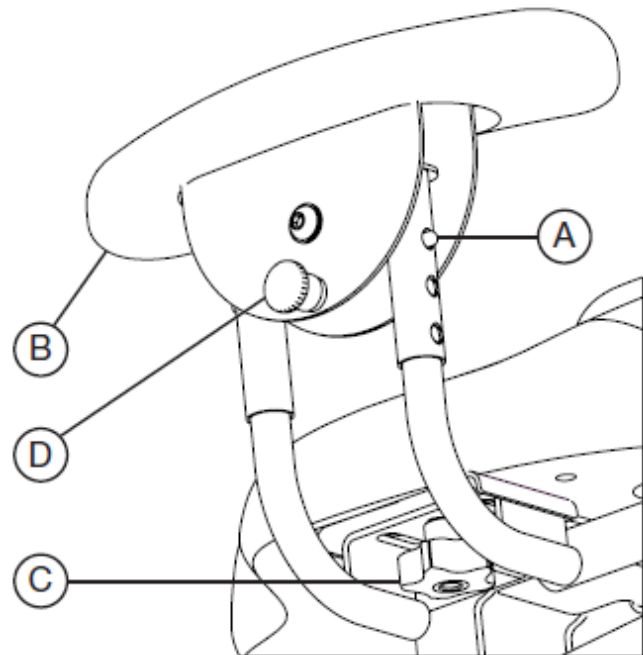

6.4 PELVIC STRAP

6.4.1 PELVIC STRAP ADJUSTMENT

- Release either clip (A).
- Seat user in the chair.
- Ensure user is seated with lower back against the lumbar prompt.
- Re-connect clip (A).
- Pull simultaneously on straps (B).
- Maintain the position of the user in the chair.
- Place ends of straps inside sleeve (C).
- Do not over tighten.

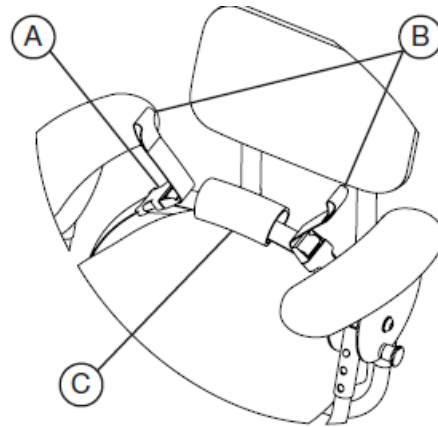

6.4.2 PELVIC STRAP ATTACHMENT

- Remove the lumbar prompt (see 6.2).
- Thread the lower ends of the lumbar prompt tubes (D) through the looped ends (E) of the pelvic strap (B).
- Slide up locating rings (I) below looped ends (E).
- Insert ends of lumbar prompt tubes (D) into receivers (F).
- Tighten handwheels (H).
- Anchor the other end of the pelvic strap to the underside of the seat using handwheels (G).

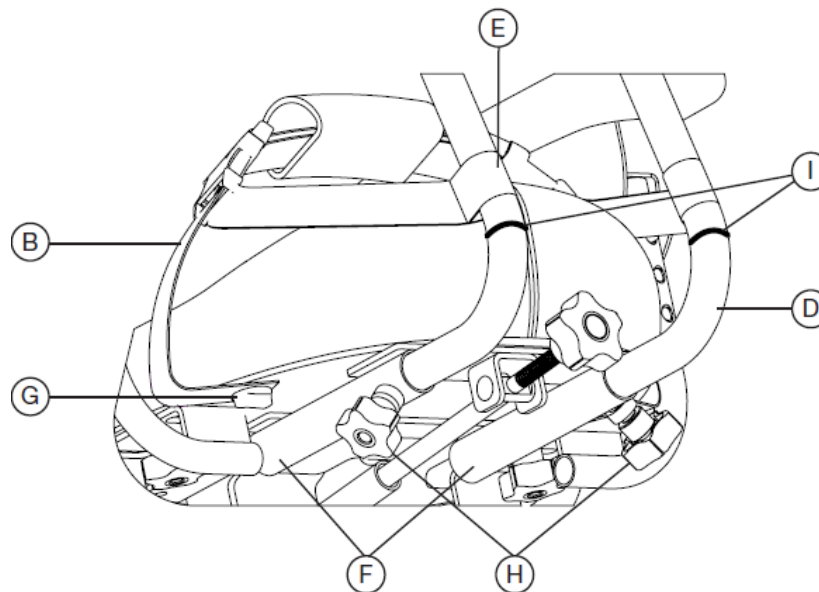

6.5 FOOTREST

6.5.1 FOOTREST ADJUSTMENTS

HEIGHT:

- Loosen handwheel (A).
- Slide footrest (B) up or down to the desired position.
- Re-tighten handwheel (A).

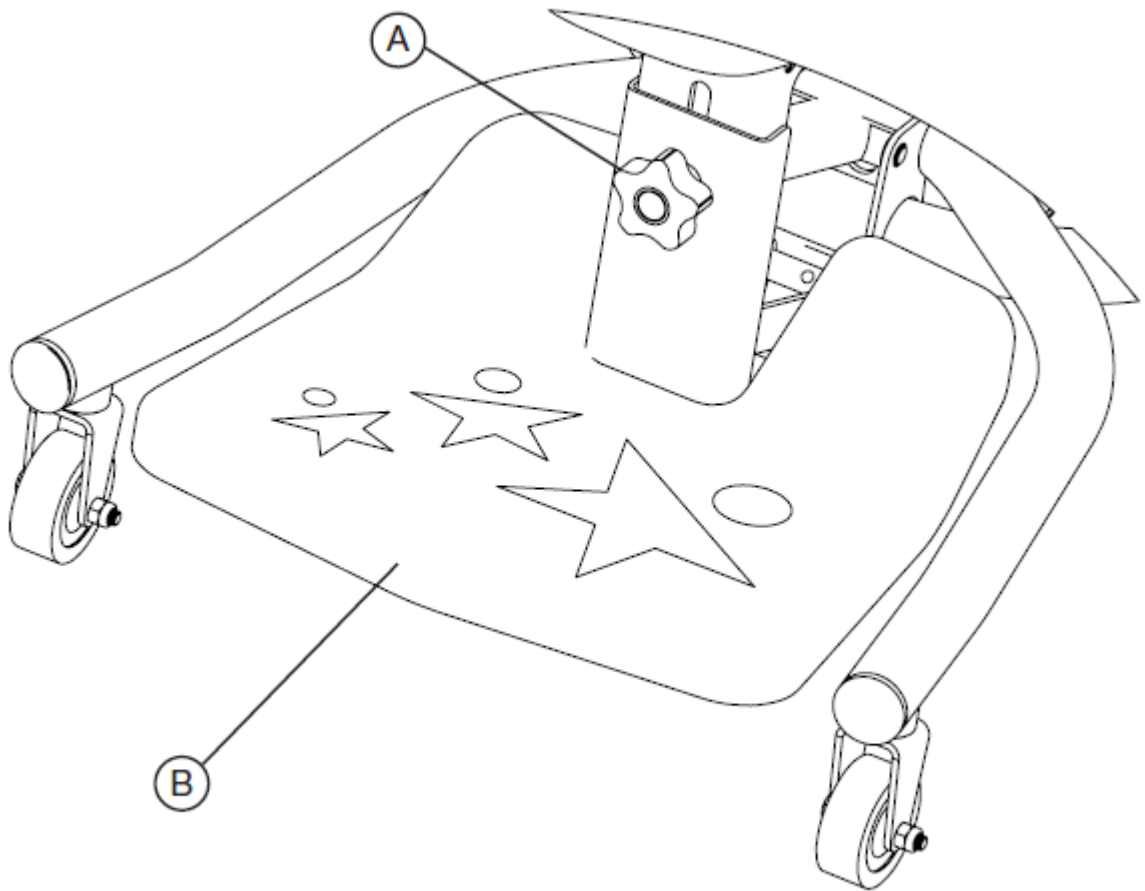

7.0 CARE AND MAINTENANCE

	IMPORTANT!
	Cleaning is recommended on a regular basis

- A damp soft cloth with mild soap to clean the seat cover and base is recommended.
- Rinse with a clean damp cloth and dry.
- A soft brush maybe used to remove severe or stubborn stains.
- DO NOT soak or immerse the chair in water.
- DO NOT use solvents, abrasives, synthetic detergents, wax polishes, antibacterial sprays or wipes.
- Household bleaches can be used if diluted to no greater than 5% proof.
- The pelvic strap can be cleaned with a damp cloth. In cases of extreme soiling it can be machine washed at a low temperature and MUST be drip dried.
- ALWAYS ensure the product is dry before use.
- ALWAYS keep the product away from naked flames, cigarettes and source of heat including open fireplaces, radiators and heaters.
- For further information please refer to MHRA or Local Authority cleaning guidelines.

7.1 DAILY CHECKS

- Check the accessories for damage or loose connection points.
- Check all upholstery for signs of wear and tear.
- Check the castors are running freely and brakes are in working order.
- Keep all parts clean.
- Check that all clamping and positional components are working, secure and free from damage.

	STOP!
	The user should not be seated while the checks are carried out.

7.2 SERVICE INTERVAL

The Strato Chair should be serviced every year. Servicing must only be undertaken by a Smirthwaite service engineer, or by a Smirthwaite trained representative.

8.0 GUARANTEE & SERVICE

The chair is issued with a full parts and labour guarantee for 2 years from the date of delivery. This guarantee does not apply to accidental damage caused through inappropriate use of the chair. This guarantee is issued at the discretion of G&S Smirthwaite Ltd on RTB (Return to Base) basis.

If you have any questions or doubts relating to the safety or use of the chair please contact us for advice or assistance on:

T: +44 (0) 1626 835552

E: info@smirthwaite.co.uk

9.0 CONTINUOUS IMPROVEMENT

G&S Smirthwaite Ltd are committed to continuous improvement to their product range. Should you have any suggestions or comments please send them to our product design department at: info@smirthwaite.co.uk

G&S Smirthwaite Ltd reserve the right to change the specification or material without prior notice.

For catalogues, help and further information on our products please contact us at:

G&S Smirthwaite Ltd
17 Wentworth Road
Heathfield
Devon TQ12 6TL

T: +44 (0) 1626 835552

F: +44 (0) 1626 835428

E: info@smirthwaite.co.uk

W: www.smirthwaite.co.uk

10.0 WARRANTY & AFTERSALE

10.1 Product Information

Model:	
Size:	
Date of Manufacture:	
Serial Number:	

10.2 Service & inspection record form:

Date	Procedure	Service Personnel



G&S Smirthwaite, 17 Wentworth Road, Heathfield, Newton Abbot, Devon.TQ12 6TL
T: +44 (0) 1626 835552 F: +44 (0) 1626 835428 E: info@smirthwaite.co.uk
W: www.smirthwaite.co.uk