

Juni Chair

INSTRUCTIONS FOR USE

Codes 16011-16014, 16021-16024, 16031-16034



CONTENTS	PAGE
1.0 INTRODUCTION	1
2.0 ILLUSTRATION OF YOUR CHAIR	2
3.0 FOR YOUR SAFETY	3
4.0 UNPACKING AND ASSEMBLING YOUR CHAIR	4
5.0 SETTING UP AND ADJUSTING YOUR CHAIR	5
6.0 CARE & MAINTENANCE	12
7.0 GUARANTEE & SERVICE	13
8.0 CONTINUOUS IMPROVEMENT	13
9.0 WARRANTY & AFTERSALE	14

1.0 INTRODUCTION

Thank you for choosing your new Smirthwaite Juni Chair.

The Juni has been designed for children who require minimal levels of postural support when seated. It's simple, unobtrusive design style fits well into nursery, school and home environments.

	<p>IMPORTANT!</p> <p>These instructions should be read by all therapists and carers using the equipment and should be retained for future reference. The product should always be used under adult supervision.</p> <p>Any incorrect use of the product and failure to follow the instructions may put the user at risk or impede the function. If you have any queries using this product or wish for further copies, please do not hesitate to contact Customer Service department on T: +44 (0) 1626 835552.</p>
---	--

2.0 ILLUSTRATION OF YOUR JUNI CHAIR

- A. Contoured seat
- B. Adjustable backrest
- C. Adjustable armrest
- D. Outrigger legs

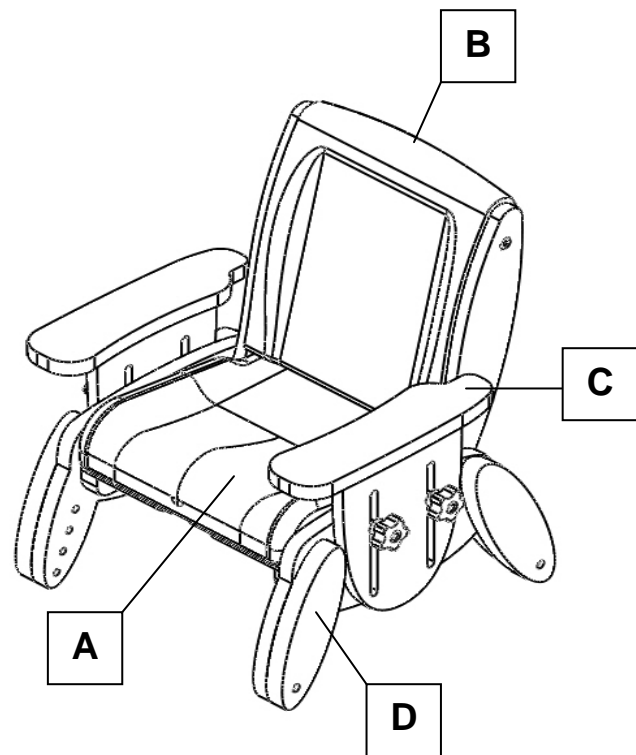

2.1 TECHNICAL DATA

Chair

Size	height	width	depth	back height	back angle	weight limit
1	160-220	240	180-240	260	95/100/105	30
2	200-280	280	220-300	290	95/100/105	40
3	240-340	325	260-360	325	95/100/105	50
4	300-400	365	320-420	400	95/100/105	60

3.0 FOR YOUR SAFETY

	STOP!
	Please read these instructions CAREFULLY and THOROUGHLY

- The user should NOT be left unattended whilst using the chair. Always ensure a responsible adult or carer is in attendance.
- The carer should be familiar with the methods of adjustment and have completed all adjustments appropriately to meet the needs of the child before use.
- Regular maintenance checks and cleaning are essential for the safe use of this equipment (see care and maintenance section).
- If any part is loose, damaged or functioning incorrectly, do not use until rectified.
- Always fasten the pelvic strap and any other straps provided.
- The mobile base accessory is for indoor use ONLY.
- Regularly check that straps or harnesses are not showing any signs of tearing or fraying and that they fasten correctly.
- Ensure that all screws and handwheels are securely tightened and that none are missing.
- Always keep this product away from naked flames, cigarettes and sources of heat including open fireplaces, radiators and heaters.
- The chair is ONLY to be used on a flat level surface.
- DO NOT fit parts or accessories of other manufacturers to this product unless authorised to do so in writing by G&S Smirthwaite Ltd. Failure to follow these instructions will not only invalidate the guarantee but could make the chair dangerous to use. G&S Smirthwaite Ltd will not accept liability for any injury or damage incurred through such malpractices. Any repairs required must be carried out by G&S Smirthwaite Ltd authorised personnel.
- The Juni is CE marked. This certifies that it meets all relevant European safety requirements.

If you believe this product to be faulty - **DO NOT USE** - Contact G&S Smirthwaite Ltd on T: +44 (0) 1626 83552.

4.0 UNPACKING AND ASSEMBLING YOUR CHAIR

- The Juni chair is supplied either fully assembled or in part assembled form, for the customer to undertake final assembly – see guide below. For a detailed guide refer to Section 5.
- A part assembled Juni is supplied with the seat cushion (A) removed and the back cushion fully rotated forward (B). The back cushion is held secure for transport by setting each armrest (C) in a low position once the back cushion has been rotated forward. Leg outriggers (D) are set to minimum height as standard.
- No tools are required to finalise assembly, simply use the handwheels and washers provided.
- Firstly, loosen the handwheels securing each armrest, and raise them to permit the back cushion to be rotated to vertical or slight rearward recline. Insert a handwheel and washer (E) in each chair side.
- Offer up the seat cushion (A) to the Juni chair and secure using two handwheels and washers (F) on the underside of the chair.

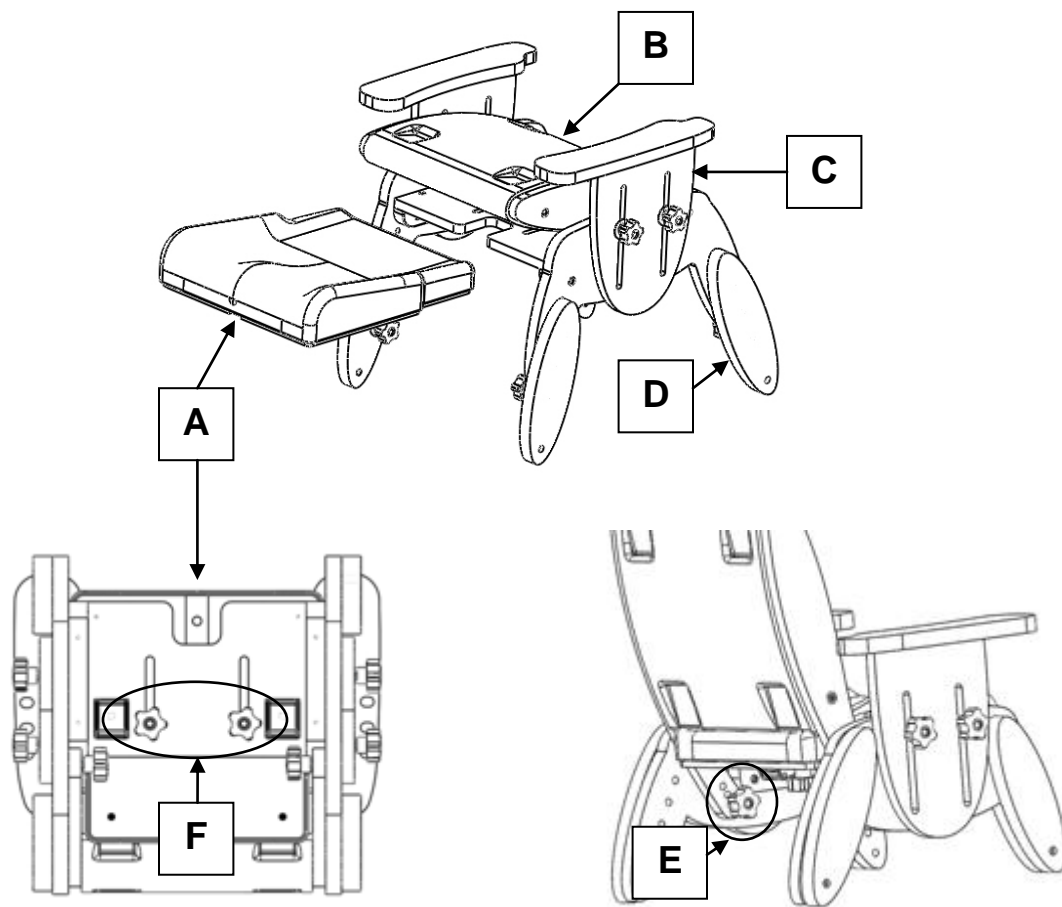

5.0 SETTING UP AND ADJUSTING YOUR JUNI CHAIR

	STOP!
	<p>If in any doubt, ALWAYS seek ADVICE.</p> <p>Always turn handwheels and screws clockwise to tighten or anti-clockwise to loosen. The chair must be fully adjusted by a therapist or trained representative before use.</p> <p>A hexagon key is provided for adjustments.</p>

	<p>IMPORTANT!</p> <p>We recommend that the chair is fully adjusted to fit the child before use.</p>
---	---

5.1 SEAT

5.1.1 SEAT ADJUSTMENTS

Five adjustments can be made to the seat; height, depth, width, back recline and back lumbar support adjustment.

5.1.2 HEIGHT

To adjust seat height

- Your Juni chair is fitted with four outrigger legs (A), permitting seat height adjustment
- To adjust, firstly lay the chair on its back
- For each outrigger, identify and remove the securing screw (M6 x 30) (B) to permit outrigger removal
- Position each outrigger leg to the desired height
- Insert and tighten each securing screw to affix leg outrigger in place
- Ensure all 4 legs are set to the same height

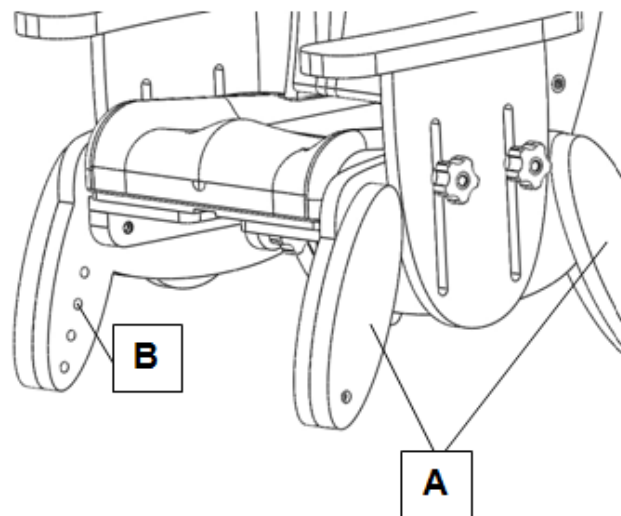

5.1.3 DEPTH

To adjust seat depth

- Loosen handwheels (C) and (D)
- Slide seat forwards or backward to desired position
- Tighten handwheels (C) and (D)

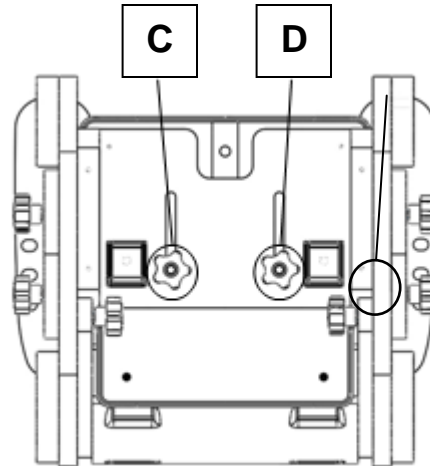

5.1.4 WIDTH

To reduce seat width or to provide additional support

- 25mm and 50mm width trunk support cushions can be supplied.
- Cushions are secured to the inside face of the arm rest wood, using the Velcro strips provided.

5.1.5 BACK RECLINE

To adjust seat back recline angle

- Locate and remove the two handwheels securing the seat back recline angle (E)
- The Juni seat back can be reclined in steps of 5° from 95° through to 105°
- When the desired back recline angle has been achieved, simply insert and tighten the two handwheels (E)

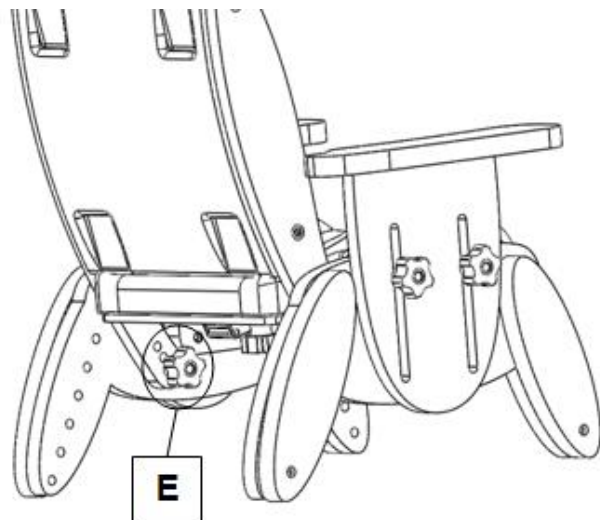

5.1.6 BACK LUMBAR PROMPT

To adjust seat back lumbar prompt

- To adjust the lumbar prompt, insert the hex head tool (as supplied) into rear of the Juni seat back (F), and rotate to achieve the desired amount of prompt

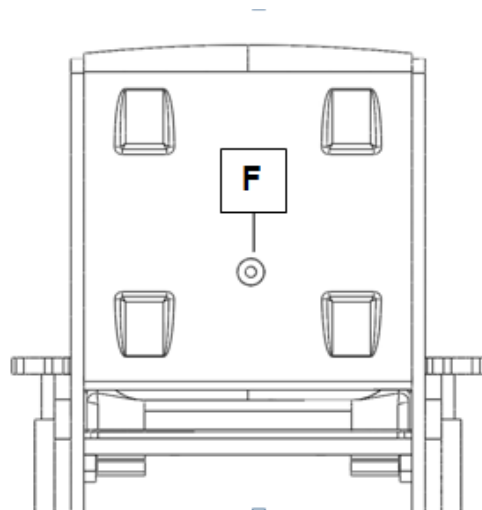

5.2 ADJUSTABLE ARMREST

5.2. 1 HEIGHT

To adjust armrest height

- Loosen hand wheels and washers (G, H)
- Slide arm rest up or down to the desired position.
- Tighten hand wheels (G, H)
- Repeat on opposite side of chair
- Ensure arm rests are at the same height and horizontal – this is particularly important if the chair is to be used with the tray accessory

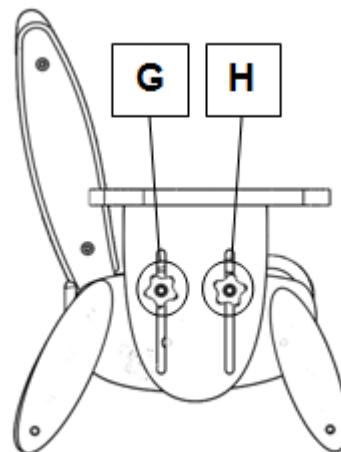

5.3 PELVIC STRAP

- The pelvic strap is secured to the seat by two cam-lock mechanisms, located under the seat base (I, J)
- To adjust the strap for growth, simply lift each cam-lock to release, adjust the strap appropriately and then close each cam-lock

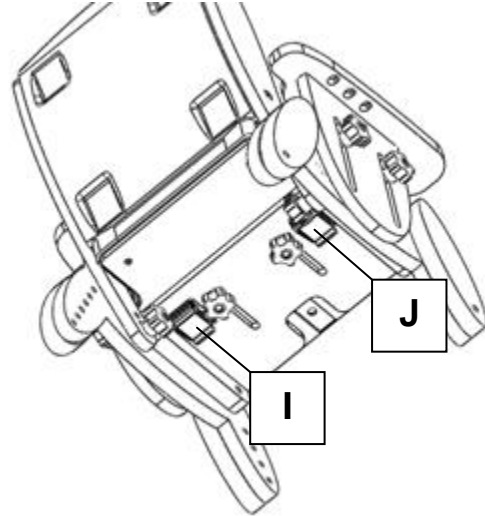

Buckle Strap (Standard)

- The buckle is secured by pushing the male plug into the female receiver
- To release the buckle, press both sides of the male plug
- The strap length can be altered by adjusting the tri-glide (as shown opposite)



5.4 TRAY ACCESSORY

- Check armrests are set to the same height, and are securely tightened
- Slide the tray onto the armrests, to the desired position – the tray will automatically lock into position
- To remove tray, pull the quick release lever on the underside of the tray, and pull the tray forward
- Ensure the protective film on the tray is removed before use



5.5 SKI ACCESSORY

- The static ski accessory is fixed to the Juni chair by 4 x M6 screws (K), which locate through each Juni chair outrigger
- A slot is designed into the rear of each static ski, this facilitates ski fitment if height of chair is adjusted
- Ensure the screws are tight at all times

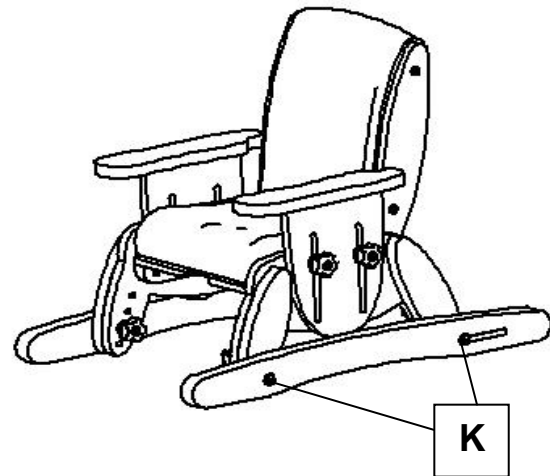

5.6 POMMEL ACCESSORY

- The Pommel accessory (L) slides over the front of the seat cushion and is fixed to the Juni using the supplied hand wheel (M)
- The Pommel can remain in place when the seat depth is adjusted

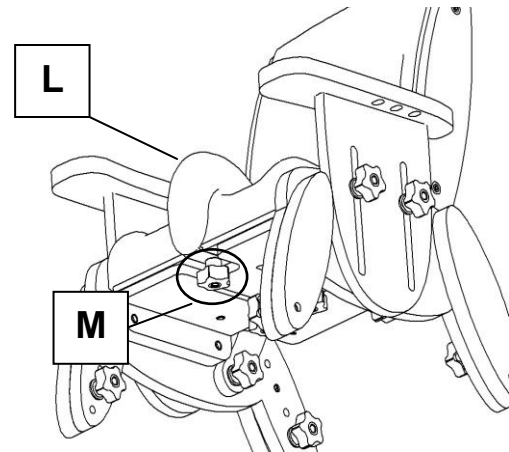

5.7 MOBILE BASE, RETRACTABLE FOOTBOARD AND HEIGHT ADJUSTABLE HANDLE ACCESSORIES

- The mobile base accessory is fixed to the Juni chair by 4 x M6 screws (N), which locate through each Juni chair outrigger
- The rear castors can be locked by applying pressure to the foot lever (Q). An adjustable height handle accessory is available, with soft grip. The height can be adjusted by unlocking clamps (P), adjust to the desired height, and then retightening the clamps (P)

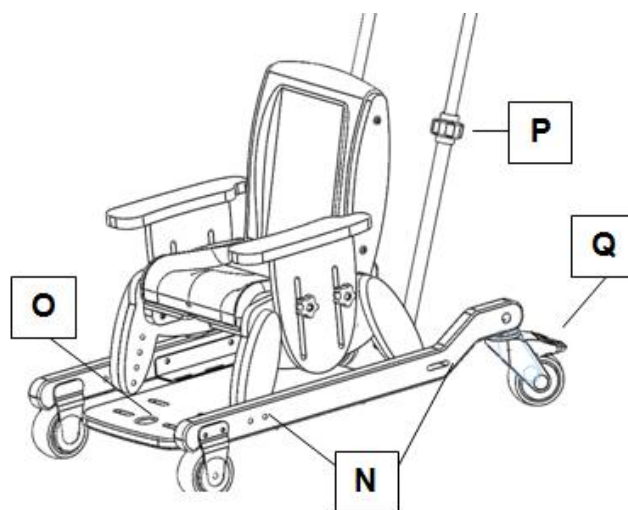

- The Retractable footboard accessory permits easy transfer into the chair. To retract the footboard, simply press the Red button (O) and push the board rearwards.

- The adjustable handle is secured to the inside face of the rear Juni legs
- Remove the M6 screw (R) that fixes the outrigger (S) to the main leg assembly (T)
- Offer up the handle bracket, and re-insert the M6 screw (R), securing both the bracket and outrigger back into place
- Repeat for the second rear leg

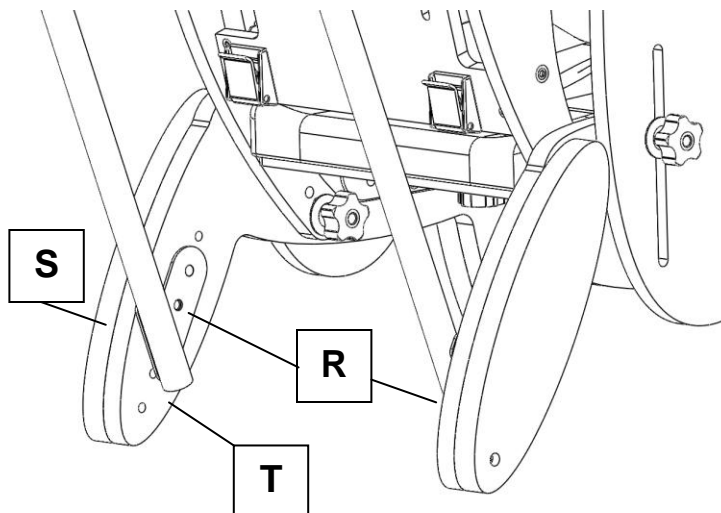

5.8 FOUR POINT HARNESS ACCESSORY

- A four point harness is available as an accessory
- The rear of the Juni seat back has 4 recesses that are designed to locate fixing cam-locks for the four point harness
- Take a sharp implement and pierce each recess where the 'dimple' is visible on the surface (U)
- Offer up a cam-lock and using an M6 screw, fasten the cam-lock to the seat
- Repeat for the 3 remaining cam-locks (V)
- The 4 point harness can now be secured using the cam-locks

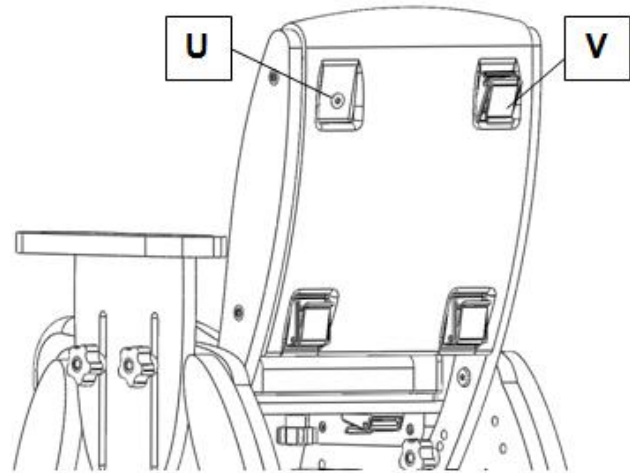

6.0 CARE AND MAINTENANCE

All our wooden chairs are easy to clean. Each chair has anti-bacterial properties, ensuring that surfaces are kept hygienic to reduce any risk of cross infection.

	IMPORTANT!
	Cleaning is recommended on a regular basis.

- Clean upholstery and wooden parts with a damp cloth and mild detergent.
- Stubborn marks on the woodwork should be cleaned by using a soft brush.
- Do not soak or immerse the chair in water.
- The pelvic strap can be cleaned with a damp cloth. In cases of extreme soiling it can be machined washed at low temperature with mild detergent but must be drip dried.
- Store the chair in a cool dry place and out of direct sunlight.
- DO NOT use bleach, solvents, abrasives, synthetic detergents, wax polishes, antibacterial sprays or wipes.

For further information please refer to MHRA or your NHS cleaning guidelines.

6.1 DAILY CHECKS

- Check the tray (if supplied) to ensure no parts are loose or damaged.
- Check all upholstery for signs of wear and tear.
- Check that the hand wheels tighten correctly, and are not cross-threaded or damaged.
- Check all straps for fraying, and that buckles are not missing/damaged.

	STOP!
	The user should not be seated while the checks are carried out.

6.2 SERVICE INTERVAL

The Juni chair should be serviced every 3 years. Servicing must only be undertaken by a Smirthwaite service engineer, or by a Smirthwaite trained representative.

7.0 GUARANTEE & SERVICE

The chair is issued with a full parts and labour guarantee for 2 years from the date of delivery. This guarantee does not apply to accidental damage caused through inappropriate use of the chair. This guarantee is issued at the discretion of G&S Smirthwaite Ltd on RTB (Return to Base) basis. If you have any questions or doubts relating to the safety or use of the chair please contact us for advice or assistance on:

T: +44 (0) 1626 835552
E: info@smirthwaite.co.uk

8.0 CONTINUOUS IMPROVEMENT

G&S Smirthwaite Ltd are committed to continuous improvement to their product range. Should you have any suggestions or comments please send them to our product design department at: info@smirthwaite.co.uk.

G&S Smirthwaite Ltd reserve the right to change the specification or material without prior notice.

For catalogues, help and further information on our products please contact us at:

G&S Smirthwaite Ltd
17 Wentworth Road
Heathfield
Devon TQ12 6TL

T: +44 (0) 1626 835552
F: +44 (0) 1626 835428

E: info@smirthwaite.co.uk
W: www.smirthwaite.co.uk

9.0 WARRANTY & AFTERSALE

9.1 Product Information

Model:	
Size:	
Date of Manufacture:	
Serial Number:	

9.2 Service & inspection record form:

Date	Procedure	Service Personnel



G&S Smirthwaite, 17 Wentworth Road, Heathfield, Newton Abbot, Devon.TQ12 6TL
T: +44 (0) 1626 835552 F: +44 (0) 1626 835428 E: info@smirthwaite.co.uk
W: www.smirthwaite.co.uk